

# Specifications:

# 56H HYDROSTART™ Hydraulic Starter

## DIMENSIONAL DATA TDI 56H HYDROSTART

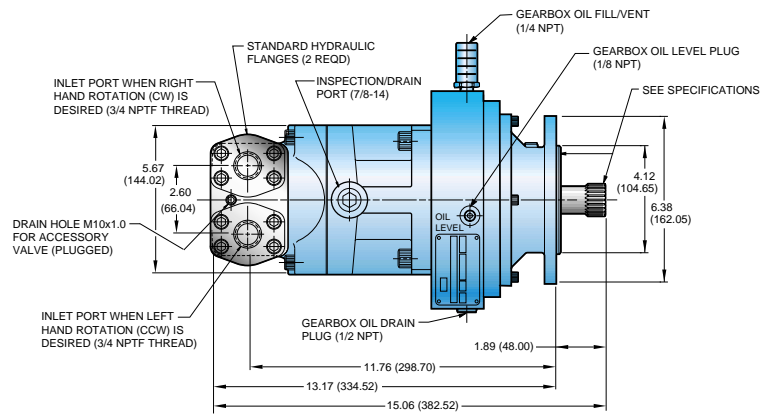

56H Series Hydraulic Starters from TDI can replace hydraulic starters costing thousands more. Power-matched for performance, and a superior strength clutch design create a solid value for starting many industrial gas turbines.

